

CÁT SAN LẤP, $\phi = 9^{\circ}53'$, $\gamma = 1.8 \text{ g/cm}^3$
 MẶT ĐẤT TỰ NHIÊN
 SÉT NÀU, TRẠNG THÁI ĐÈO MỀM
 MỨC NƯỚC NGẦM
 $c = 0.14 \text{ kg/cm}^2$
 $\phi = 9^{\circ}53'$
 $\gamma = 1.823 \text{ g/cm}^3$
 $\gamma_{dn} = 0.853 \text{ g/cm}^3$
 $E = 26 \text{ kg/cm}^2$

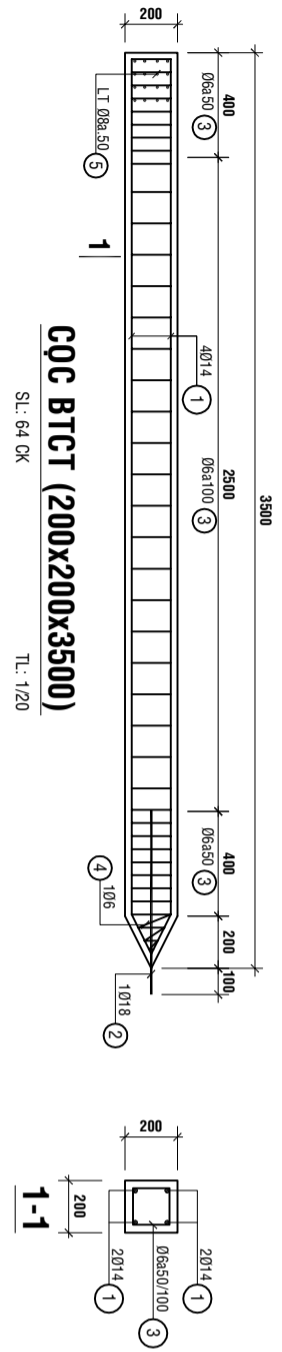

SÉT, XÂM XANH
 TRẠNG THÁI NHỎ CHẤY
 $c = 0.095 \text{ kg/cm}^2$
 $\phi = 5^{\circ}47'$
 $\gamma = 1.636 \text{ g/cm}^3$
 $\gamma_{dn} = 0.662 \text{ g/cm}^3$
 $E = 13.47 \text{ kg/cm}^2$

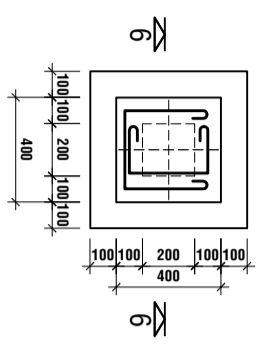
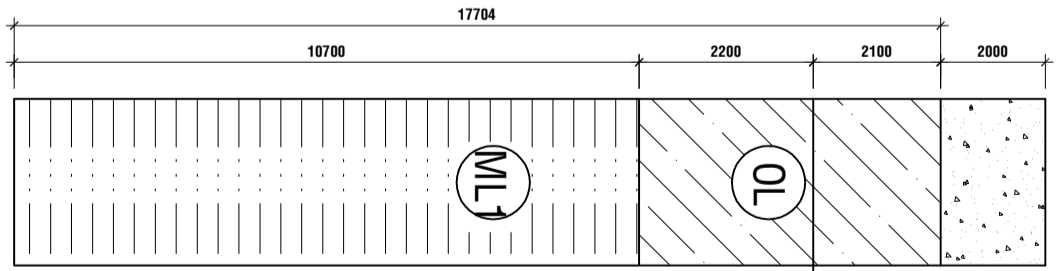

MẶT BẰNG MÔNG M
 (400x400) S.L: 64 CK, T.L: 1/20

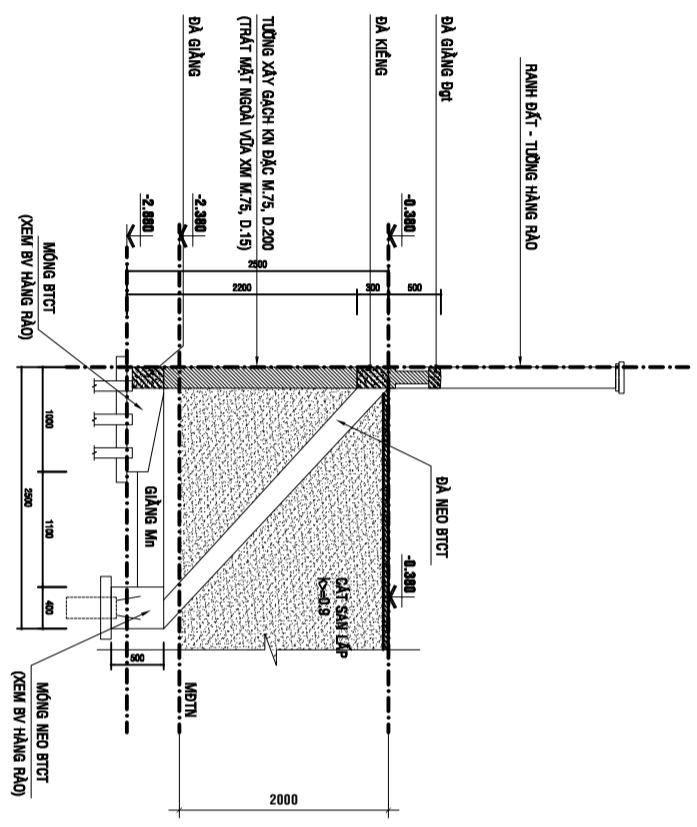

MC 1 - 1

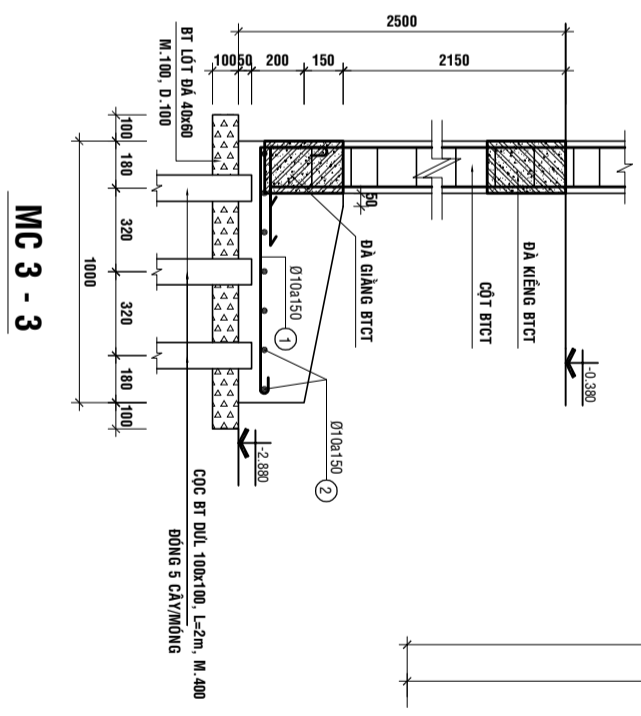

MC 3 - 3

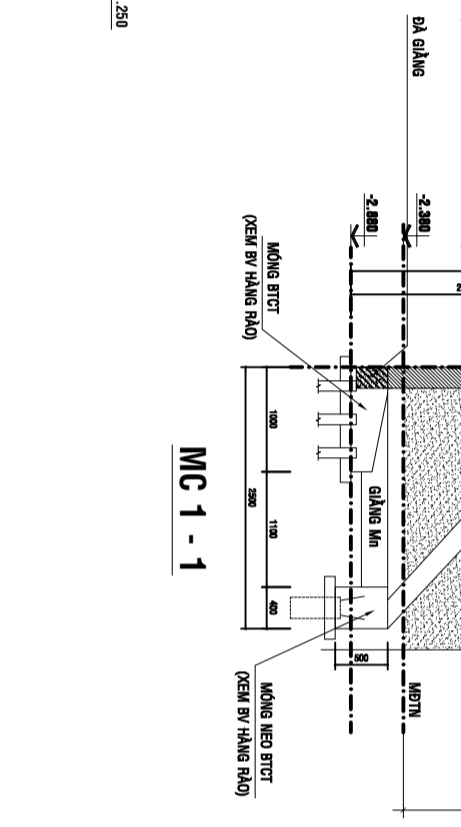
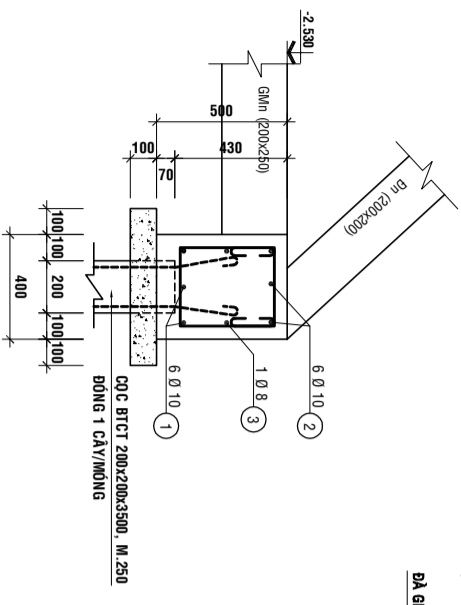

MC 1 - 1